

ASSEMBLY MANUAL



⚡ **ZAGI-400 X** ⚡

⚡ **ELECTRIC** ⚡

Wing Span	48"
Wing Area	3.33 SqFt
Airfoil	Zagi 999
Weight	24.6 oz
Loading	7.4 oz/sq.ft
Radio	3 Channels, w/ mixer

Visit: www.Zagi.com Email: Zod@Zagi.com Voicel: (310) 301-1614 Fax: (310) 822-7695

TRICK R/C Products LLC 938 Victoria Avenue Venice, California 90291

Recommendations and Notes

To avoid injury or damage to electronic speed control, Do not plug the battery into the speed control until all of the steps have been followed on page 15.

The ZAGI-400 X is not a combat or bungee launch airplane. The design objectives were to make a rugged low cost, light weight, aerobatic electric flying wing.

Read the entire manual before beginning construction!

The target weight for the Zagi-400 X is 24.6 oz. The airplane is designed to balance at 8" measured back from the nose. In order to achieve these two objectives, a speed 400 motor, micro servos, and a 1700 mAh 8 cell battery pack must be used. Any modifications, reinforcements or substitutions not described in this manual must be considered carefully to maintain the correct weight and balance. If all of the procedures in this manual are followed, the Zagi-400 X will not need nose weight.

A separate battery is not required for the receiver and servos. They are powered by the 8 cell (9.6 V) battery through the ESC which contains the Battery Elimination Circuit (BEC). When the motor drains the battery there is still sufficient power to control the plane.

3M Super 77 Spray Adhesive is the recommended adhesive to prime the foam before you begin covering. If a substitute adhesive is selected, test spray a piece of scrap foam before spraying the cores.

Trick R/C did not test any covering materials such as UltraCote, MonoKote, Solarfilm, or any other iron-on materials. If an alternate covering material is chosen, test a patch on the beds first. Lower heat would be necessary on the 1# white foam (the foam behind the EPP leading.)

Do not cut into any part of the leading edge foam for the radio installation or nose weight.

Do not use polyester resin, solvents, solvent-based paint, Shoe Goo or Goop on either type of foam.

Tools and materials needed:

Optional a second roll of contrasting color poly tape (see text)

90 degree square

Sanding block

150 to 320 grit sandpaper

X-Acto knife or Dremel

Round pencil or ball-point pen

5 Minute Epoxy (optional)

3M Super #77 Spray Adhesive

3/4" Fiber filament strapping tape

Soldering iron

The ZAGI-400 X Complete Kit Electric Wing Kit contents:

- 2 Expanded polypropylene (EPP) leading edges laminated to 1# white foam wing panels and beds
- 2 Pre-cut balsa elevons
- 2 24" strips of 1" x 3 mil paper backed Mylar hinge tape
- 1 Roll 2.2 mil color poly tape
- 2 Control horns with 4 screws
- 2 Threaded 2 X 56 push rods
- 2 Threaded 2 X 56 clevises
- 1 Carbon fiber spar
- 2 Die-cut clear winglets
- 1 Molded motor mount and battery tray
- 1 Molded canopy
- 1 Speed 400 motor and prop
- 1 Zagi 20 Electronic Speed Control (ESC) with Battery Eliminator Circuit (BEC)
- 1 8 cell 1700 mAh battery with Deans Ultra plug
- 2 Wire ties to secure motor
- 4 Velcro strips for canopy and battery hold down
- 1 Deans Ultra plug with red and black leads (for charging the battery)

Needed Components

- 1 Radio Transmitter (TX) 3 channels w/mixing
- 1 Receiver (RX)
- 2 Micro servos are recommended (approximately .65 ounces)

(See **Figure 1**) Separate the top and bottom beds from the wing cores. Lightly block sand the wing panels (cores) with #150 or #320 paper and round the leading edge (LE).

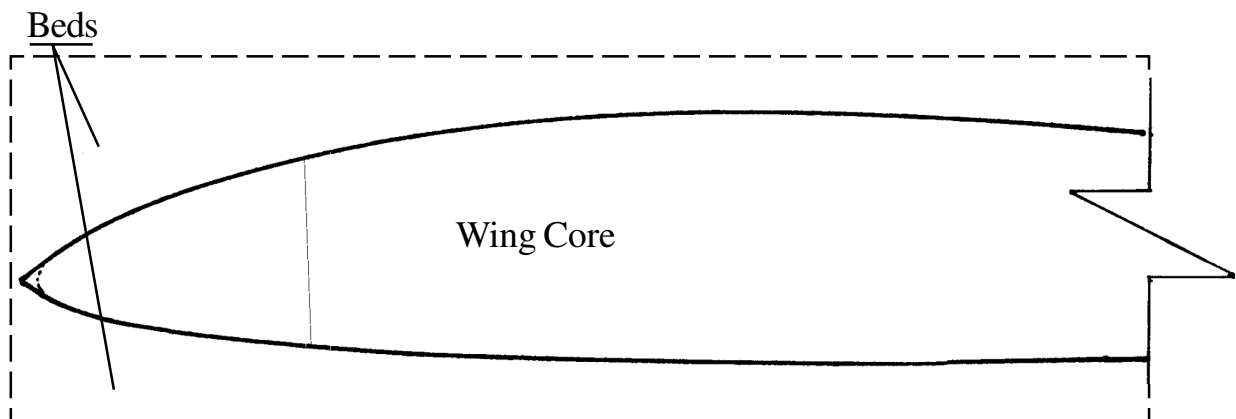

Figure 1

Layout the bottom beds on a flat surface. Tape them together. Repeat for top beds. Align the cores together on the bottom bed. Spray the root end of the wing cores with #77 spray adhesive. Put a piece of clear wrap or wax paper between the beds and the cores to prevent sticking. Let the adhesive dry for 10 minutes. Put the wing cores together using beds as a jig.

(See **Figure 2**) Measure 11 3/4" from the nose along the center line and make a mark. Use a square to measure 2 1/2" on both sides of the center line. Mark the 5" line and make two lines parallel to the center line from the ends of the line to the trailing edge (TE). Cut along the lines and remove the foam.

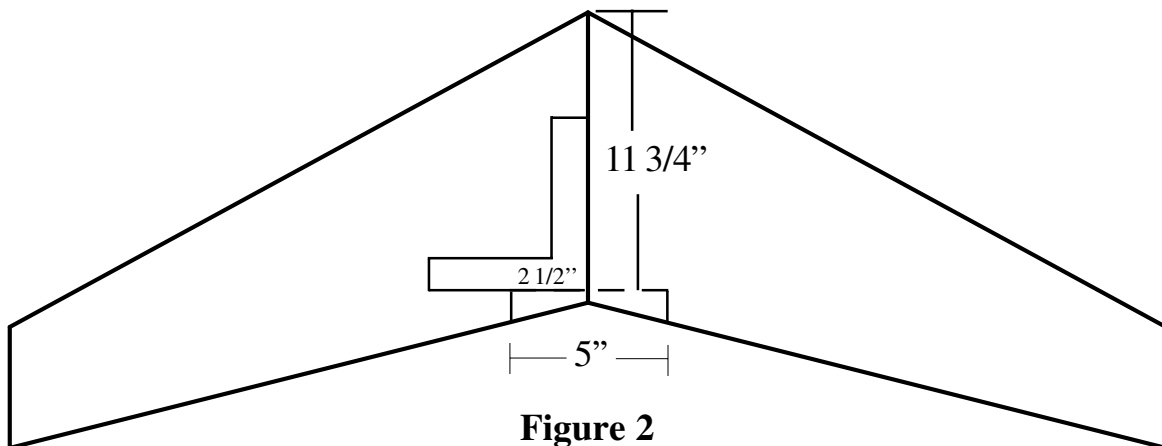

Figure 2

(See **Figure 3**) **Install the carbon spar on the bottom of the wing.** Measure 8" back from the nose and make a mark. Draw a line perpendicular to the center line from leading edge to leading edge. Router or cut a groove deep enough to bury the carbon spar. The spar may be installed with 3M Super #77 Spray Adhesive (#77) to save weight. Spray a puddle of #77 into a small cup. Spread the glue in the spar groove with a small brush or swab. Spray the carbon spar with the #77. Let the glue dry for 15 minutes. Push the spar into the slot. Let the glued spar set over night before taping over with fiber tape. Epoxy may be used instead of the #77 to save time. Let the epoxy cure and apply a layer of fiber tape over the spar.

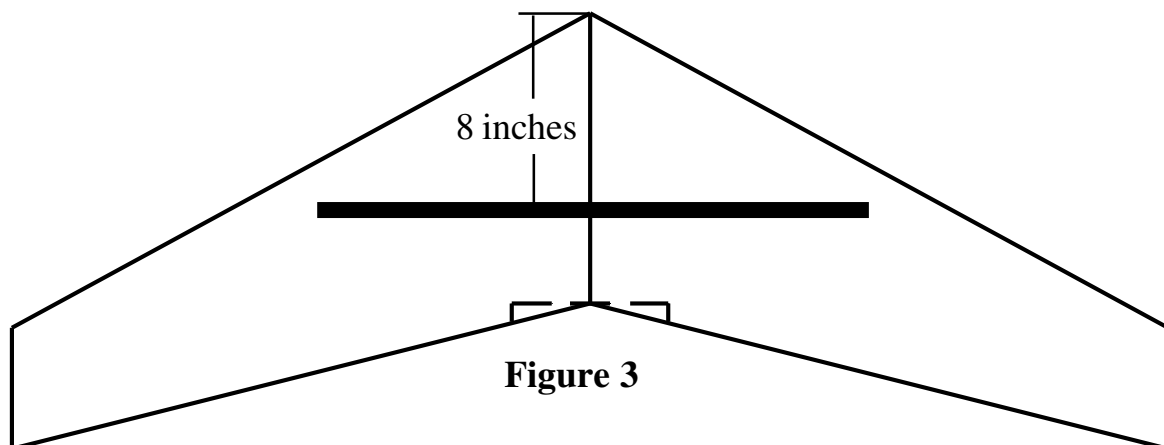
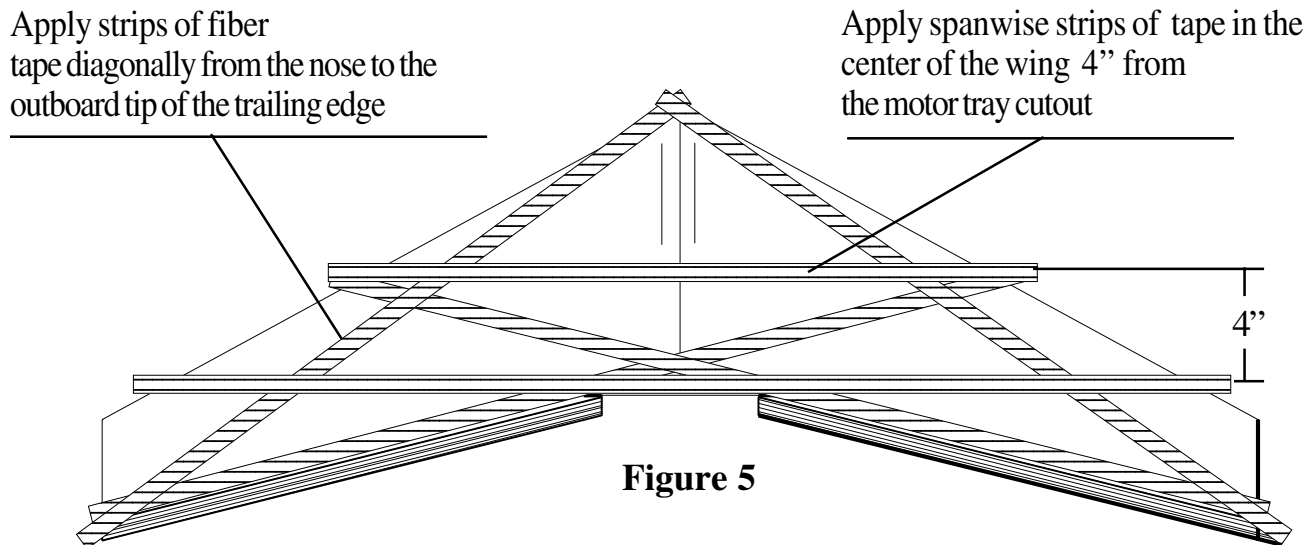
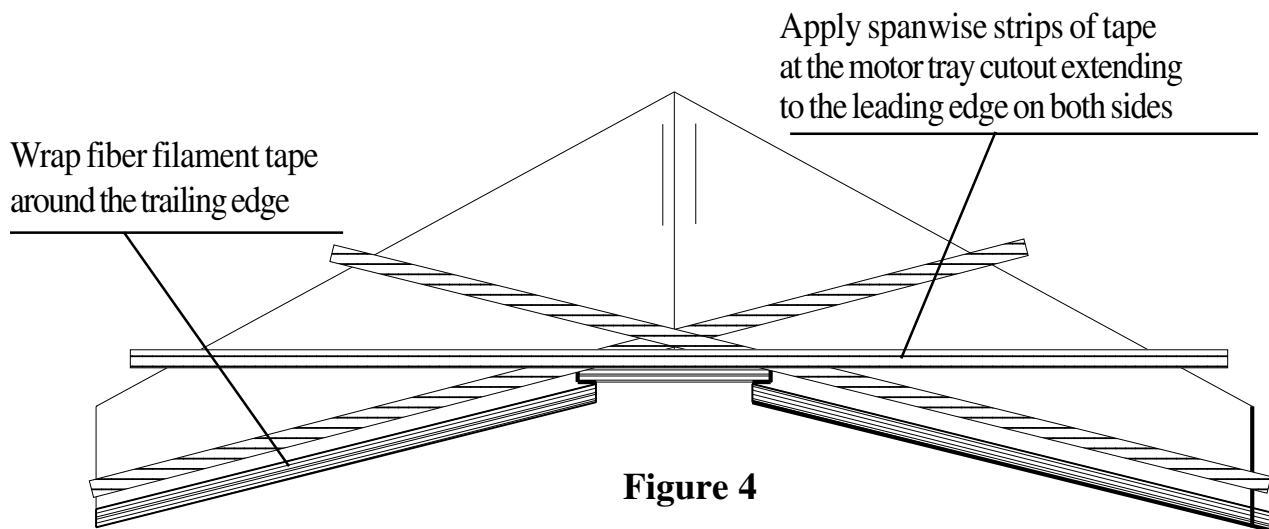

Figure 3

The ZAGI-400 X should be sprayed with #77 and covered with tape before any holes are cut for radio installation. This will avoid getting spray adhesive in the radio compartments or on the antenna. Most of the colors are transparent enough to see the servo cutout marks through the tape. If a dark color tape is used, make some small impressions with a pencil at the corners of the servo cutout marks.

(See Figure 4) Vacuum the dust from the cores, beds and the work bench. Lay the wing in the bottom beds top-side up. Apply a light coat of #77 to cover the top of the entire wing. Allow the adhesive spray to dry at least 30 minutes. Repeat this procedure on the other side. Let the adhesive dry for 30 minutes. Lay the wing top-side up in the bottom beds. Wrap a strip of 3/4" fiber filament tape around the trailing edge between the wing tip and the prop cutout. Apply a strip of fiber tape to the trailing edge from the wing tip to the opposite leading edge.



(See Figure 5) Apply another strip of 3/4" fiber tape in the center of the wing 4" from the motor tray cutout. Apply two strips of fiber tape diagonally from the nose to the outboard tip of the trailing edge. Lay the wing bottom-side up in the top beds and repeat the same taping procedure on the bottom side.

Taping Tip

Covering the top and bottom of the wing in contrasting colors makes the plane much easier to fly. Apply the darker color on the bottom surface. An optional roll of color poly tape will be required to do this.

Place weights on the wing panel opposite the side being covered. Apply the tape without stretching it. Pull a 30 inch length of tape off the roll. Hold roll in one hand and the cut end in the other. Hold the length of tape parallel to the panel about two inches above the surface. Sight directly over the panel to measure the overlap. Touch the cut end to the panel. Without stretching the tape, lower the other end of the tape.

(See Figure 6) Apply a light coat of (#77) to the fiber tape on the wing. Lay the wing in the top beds bottom-side up. Start the color covering tape at the trailing edge (TE) of the wing by wrapping a strip of color tape around the TE being careful to follow the shape. Working from the TE forward, lay strips of tape from tip to **at least 4 inches past center**. Overlap the tape only 1/4" all the way from the center to the tip. Cut the tape to match the angle of the leading edge (LE). Place the wing top-side up in the bottom beds and repeat the taping procedure working from TE forward to the LE. Finish the leading edge with a single spanwise piece of tape.

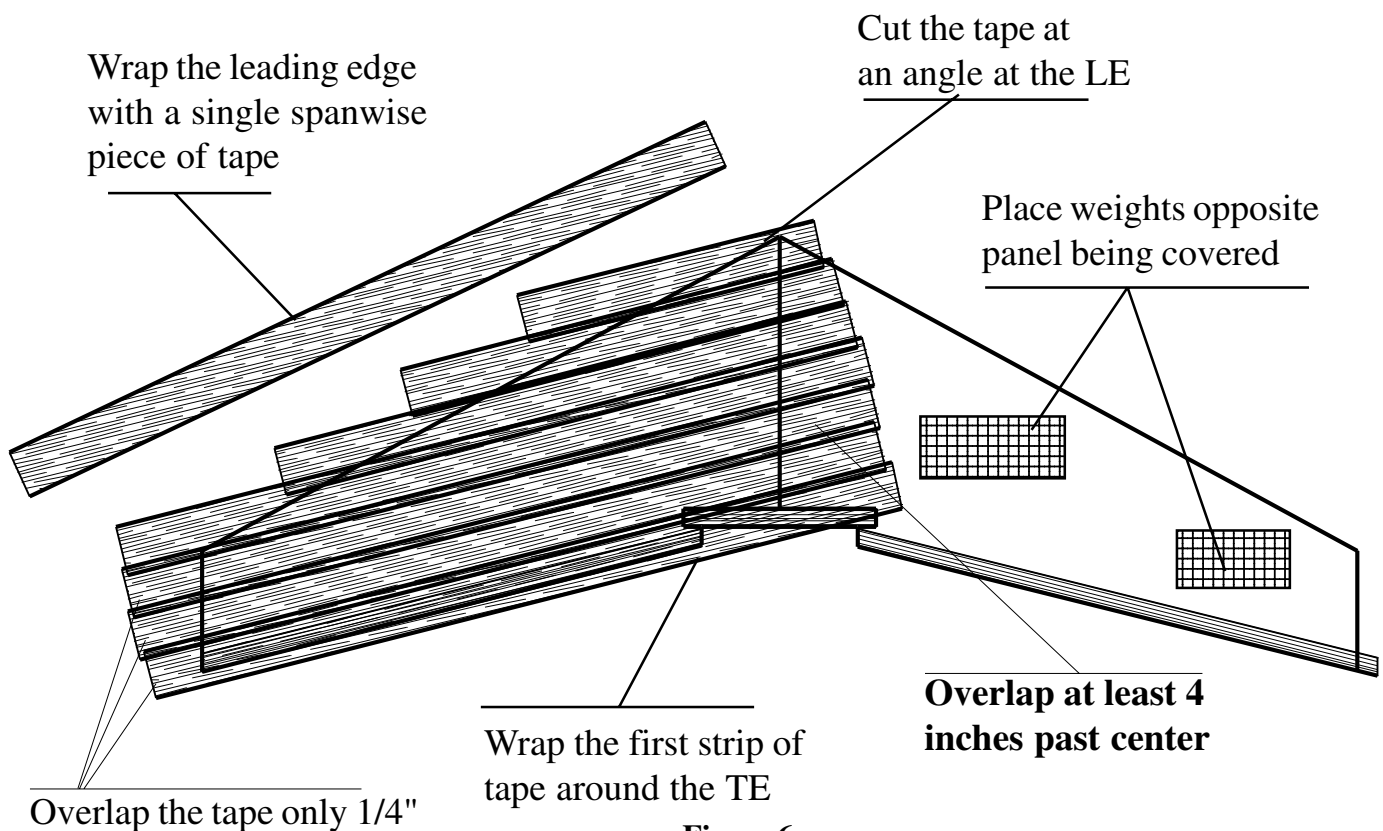
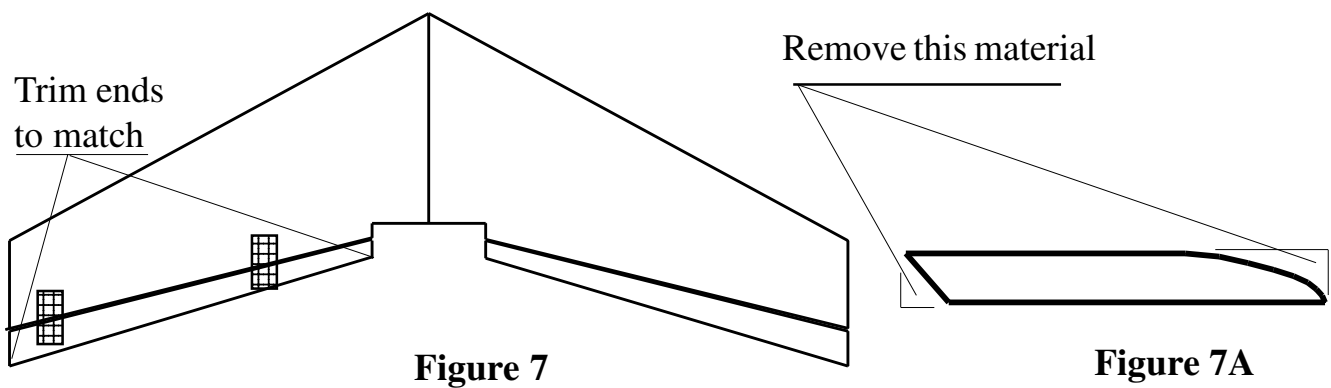

Figure 6

(See **Figure 7**) Hold the elevons together and sand them until they are identical. Trim the outboard end to match the angle of the wing tip. Trim the inboard end of the elevon to match the angle of the motor cutout. Make the elevons about 1/16" shorter than the wing tip to assure the elevons don't rub against the winglets after they are installed.

(See **Figure 7A**) Round the top of the trailing edge of the elevon. Sand a 45° angle into the front of the elevon.

Spray the elevons with any spray enamel. Primer works well. Apply a light coat of paint and immediately wipe it with a cloth before it soaks in and dries. Let the paint dry and repeat the procedure one more time. Let the paint dry completely before attaching them with the hinge tape.



(See **Figure 8A**) Make sure that the paint is dry. A strong tape bond can be achieved by spraying a light coat of #77 adhesive on the elevon before applying the hinge tape. Mask off the elevon leaving 1/2" exposed. Spray the exposed area with a light coat of #77 adhesive. Remove the masking tape. Let the #77 adhesive dry. Position the elevon on the trailing edge of the wing with a small piece of masking tape on the bottom side. Peel the paper backing from the 1" x 3 mil Mylar hinge tape. (See **Figure 8B**) On the top side align the hinge tape by holding the peeled tape over the seam. Secure the elevon by pressing the hinge tape in place at one end. Press the hinge tape down along the length of the elevon. Remove the small pieces of masking tape.

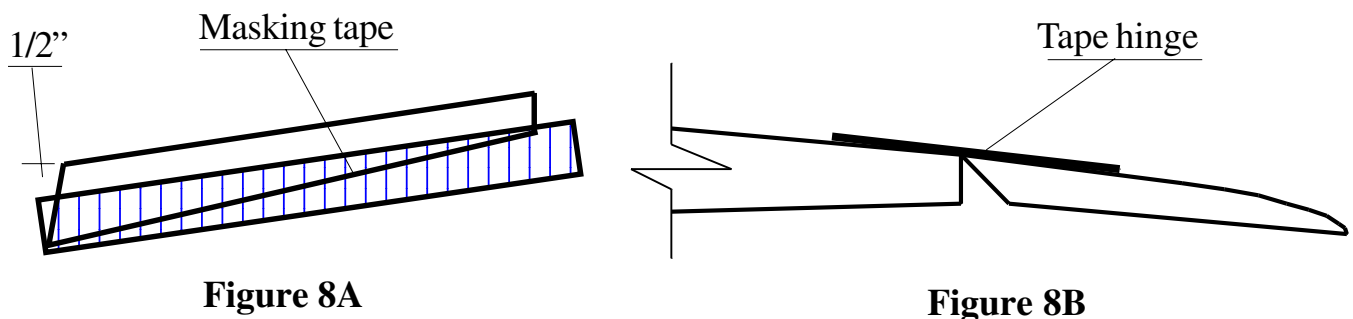

(See Figure 9) Trim the motor tray with scissors along the cut line. Notice that the cut line is the impression 1/2" from the side rails of the compartments. Leave the vertical lip at the rear of the motor tray. Trim the canopy along the cut line. The canopy cut lines are more visible when viewed from the inside. Remove the rear wall of the canopy. Cutout the rear wall of the vent slots for battery and motor cooling on the canopy. Position the motor tray over the center of the wing. Trim the vertical lip at the rear of the motor tray to be flush with the bottom of the wing.

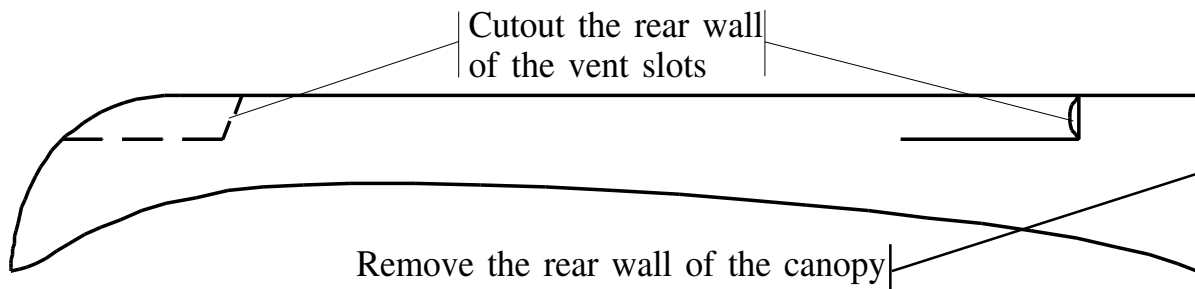

Figure 9

(See Figure 10) Position the servos on the pre-marked servo positions. Outline the exact shape. Cut or router the foam to provide a snug flush fit. Wood shims can be used to assure a tight fit.

Position the receiver 1 1/2" back from the nose. Position the receiver so that the input slots align with the centerline of the wing. Outline the exact shape. Cut or router the foam to provide a snug flush fit. Another bay can be made next to the receiver bay to hold a separate mixer or cut the bay deeper so that the mixer and all of the plugs and extra wires fit underneath. Test fit the motor tray to check the receiver position. Make a cutout in the front shelf of the motor tray to provide access to the input slots of the receiver.

NOTE: New flyers and combat pilots may choose to locate the receiver in a safer place. The nose mounted receiver is cleaner but more vulnerable to damage from the battery slamming into it in severe front impact. The alternate receiver location in figure 10 will not affect the ballance in any direction. The wing thickness will accomodate almost any size receiver.

Draw a line between the servo wire and the center line of the wing. Make a 1/2" deep cut along the line. Push the servo wires into the slot with a flat blade screwdriver. Plug the servo leads into the appropriate receiver output slot. The extra servo wires can be stowed under the motor mount tray.

(See Figure 10) Install the antenna along the leading edge seam between the two types of foam. Cut a 1/4" slot in the seam between the receiver (RX) and the wing tip. Push the antenna into the slot with a flat blade screwdriver. The antenna will extend several inches beyond the tip. Before securing the servos in place make sure that the servo arms are in the correct position. Position the two servos on the table in the proper orientation as they would be installed on the plane and connect to the receiver. Turn on the transmitter (TX) and connect a spare 4.8 V battery to the (RX). The TX should be in the elevon or mixing mode. Check the radio instruction manual for the "Elevon mixing or Delta mixing settings". Set the trim levers on the TX to zero. Install the servo arms as close to vertical as you can get. Make sure that both arms move forward when the TX stick is pulled back. Move the TX stick to the right. The servo arm on the right should move forward as the one on the left moves back. Reverse the controls in the TX as necessary. Push the servos into the servo bays. Apply a piece of color tape over the servos to hold them in place.

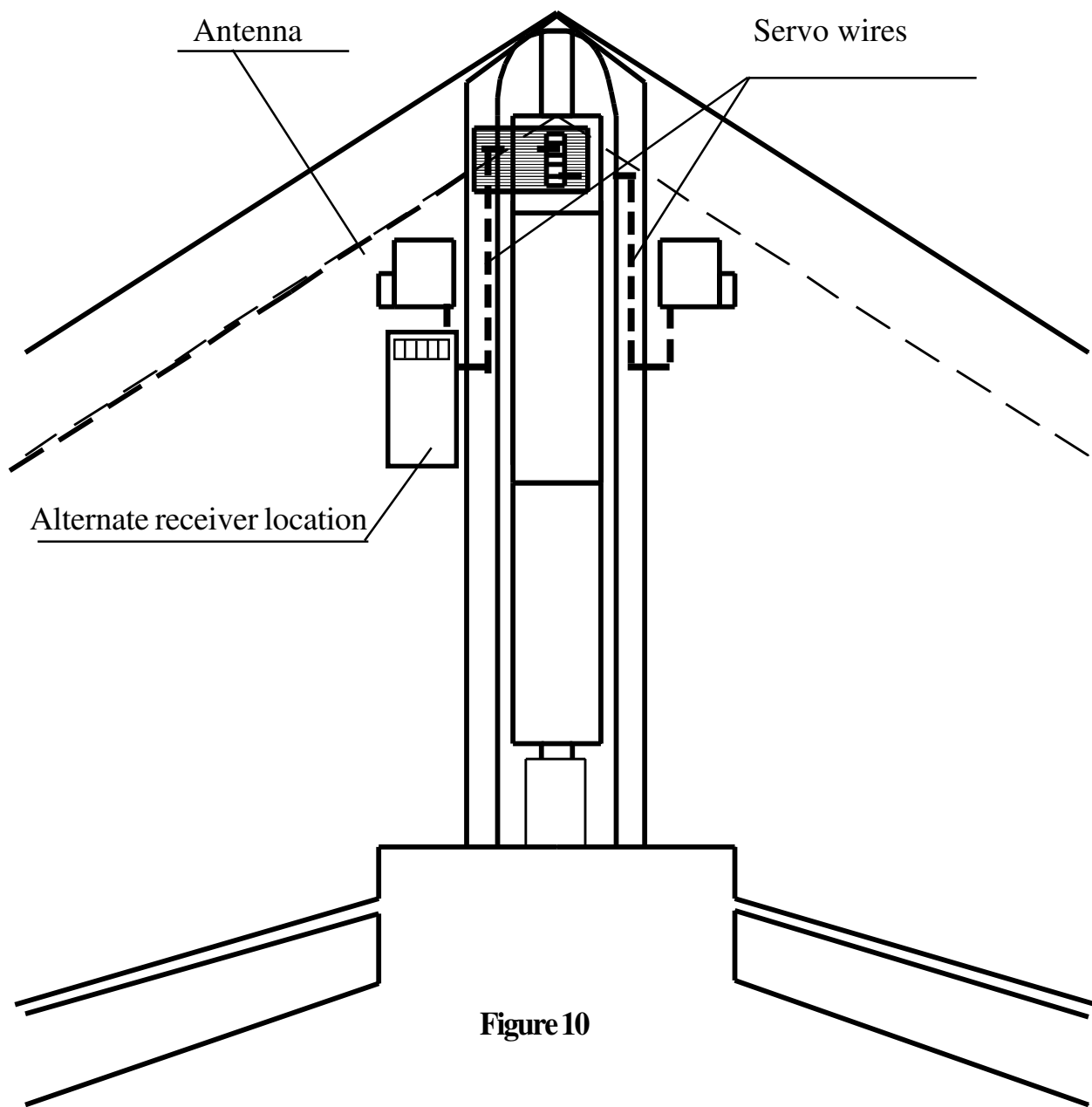

Figure 10

(See Figure 11) The control rods may not fit in the servo control arm. The end of the control rod can be filed to fit in the servo control arm or the holes in the servo control arm can be reamed by spinning an Xacto #11 blade in the hole or drilling with a #48 drill (.076"). Attach control rods to the servo control arms with a Z-bend. (NOTE: Z-bend pliers may be purchased from your local hobby store to facilitate this operation) Position the control horns on the elevon directly behind the servo control arm, close to the hinged edge. Be sure the control horn and screw plate do not interfere with the movement of the elevon. Mark the position of the control horns. Drill two holes. Install the control horns on the elevons. Note that the two screws will self thread into the plastic screw plate. Attach the control rods to the top hole of the servo control arms. Attach the clevises to the top hole of the control horns.

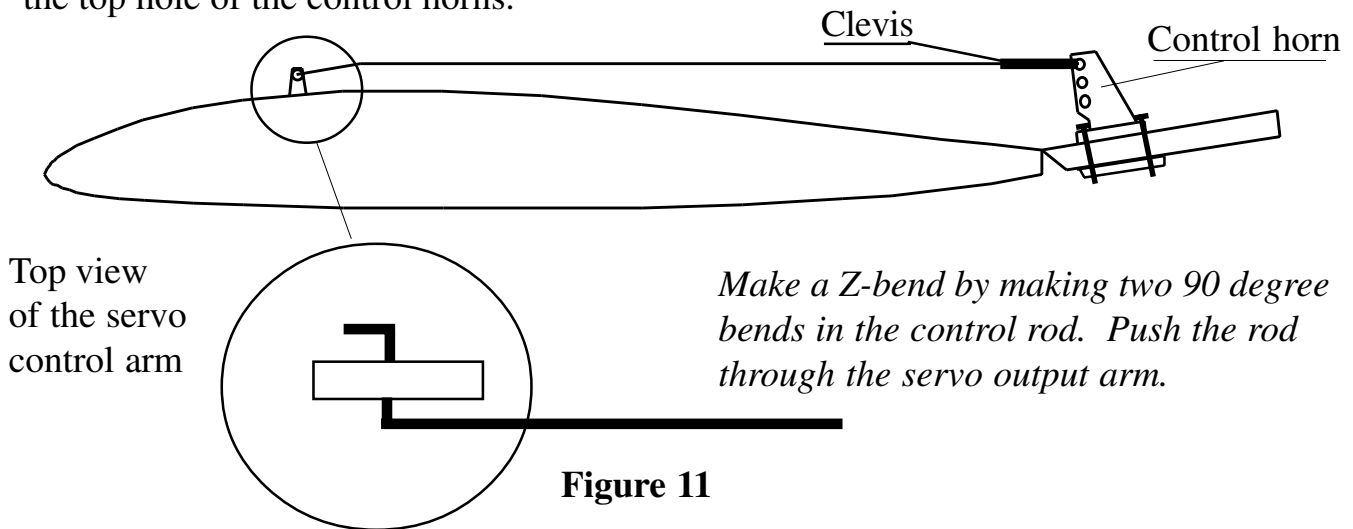
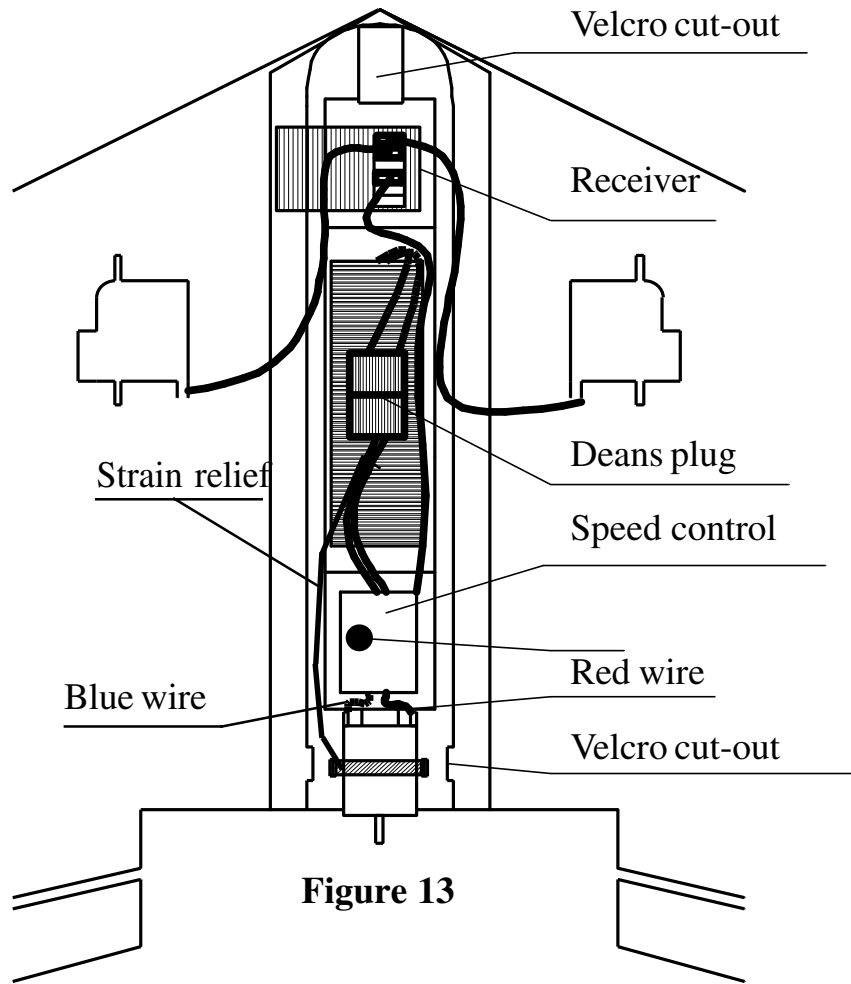

Figure 11

(See Figure 12) The Zagi-20 ESC (Electronic Speed Control) is provided in the kit. The red and black pair of wires with the red male Deans Ultra connector plugs into the battery. The red and blue pair of wires should be soldered to the motor. The Zagi-400 X uses a pusher configuration which requires a reverse rotation motor. Reversing the rotation of the motor is achieved by reversing the polarity to the motor. Look at the flat surface on the back of the motor. Observe the red dot next to one of the motor terminals. Solder the wires to the motor terminals, the blue wire on the terminal next to the red dot. The third set of wires is the cc with the universal RX servo connector. This RX connector goes to slot in the receiver to control motor speed. The three wire ribbon connector will provide power for the receiver and servos. **No other receiver battery is necessary.** The universal connector will work with all radios except the old Airtronics. The red and brown wires must be reversed in the plastic housing to change to the old Airtronics system. **Refer to the detailed ESC instruction sheet in the power pack.**

(See Figure 13) Attach the motor to the tray with a wire tie. Locate the dimples on the rails on either side of the motor mount. Spin an X-acto blade in the dimples to make a hole. Elongate the holes to fit the wire tie. Push the wire tie through from the top of the tray. Wrap the wire tie under the motor tray and through the hole on the opposite side. Set the motor in the motor mount and push forward to the stop. Thread the wire tie and pull it tight. Hold the tail of the wire tie with pliers and give it a good strong tug. Trim the tail off of the wire tie. Slide the wire tie connection to the side of the motor.



(See Figure 13) A strain relief can be made to protect the ESC wires from damage on impact. Tether the Deans connector on the ESC to the motor wire tie with a length of dental floss. The tether will unplug the battery on impact rather than pulling wires out of the ESC. **Caution: The prop SHOULD NOT be installed on the motor at this time. The speed control could turn on when the battery is plugged in. Attach the red and blue wires to the motor before the ESC is plugged into the battery.**

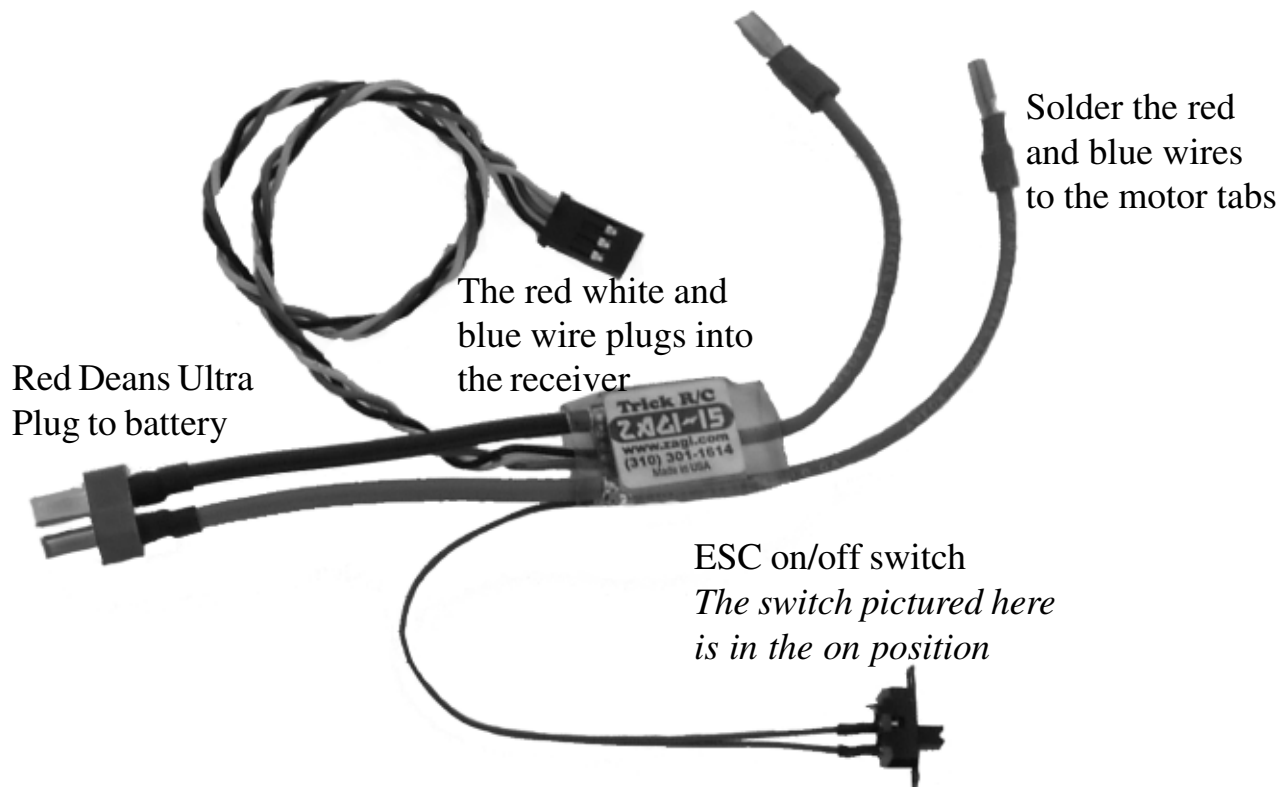

INSTALLATION AND HOOK-UP. Do not plug the battery into the ESC until all of the hook-up and power-up steps have been completed.

The ESC will power the receiver and the servos from the motor battery. Do not install a separate receiver battery. The universal receiver connector will work with all radios except the old Airtronics. The red and black wires must be reversed in the plastic housing to change to the old Airtronics system. Plug the three wire ribbon lead to receiver into the throttle slot. (NOT THE BATTERY SLOT). The red and blue pair of wires with the spade connectors should be soldered to the motor. Zagi electric wings use a pusher configuration which requires a reverse rotation motor. Reversing the rotation of the motor is achieved by reversing the polarity to the motor. Look at the flat surface on the back of the motor. Observe the red dot next to one of the motor terminals. Solder the blue wire on the terminal next to the red dot and the red wire to the other tab. Either solder the connector to the motor terminal or cut the connectors off and solder the wires to the terminals. The Red Deans Ultra Plug is the battery connector.

FIRST TIME POWER-UP. Refer to page 16 for first power-up! Do the first power-up without the prop.

Do not power up the motor unless it is secured to the motor tray. The motor body will spin in the opposite direction of the rotation and spin the ESC wires in a knot.

(See **Figure 14**) Peel the protective paper off of the hook side of two strips of Velcro. Stick the strips to the battery 1/2 inch from each end. Press the loop side to the hook side and peel the paper. Press the battery in place with the sticky side down. Use only two pieces of Velcro on the battery. The battery will stay seated in the tray and withstand the stresses of flight. On impact however, the battery should be free enough to eject so that the airframe does not have to absorb the energy. The ESC can be placed on top of the battery. Do not Velcro the ESC to the battery.

(See **Figure 15**) Cut one of the squares of Velcro in half. Stick the hook side of one of the small strips of Velcro to the nose of the motor tray. Stick the hook side of one of the small strips of Velcro to either side of the back of the motor tray in the cut outs. Put the loop side of the Velcro loop side down on the hook side. Peel the paper off of the loop side. Place the canopy over the motor tray, nose first. Spread the back end of the canopy and lower it onto the motor tray. Press the sides over the Velcro to assure that the adhesive is stuck.

(See **Figure 15**) Align the motor tray with the nose. Make sure that the motor tray is centered over the center line at the trailing edge. Attach the motor tray with a strip of fiber tape on each side.

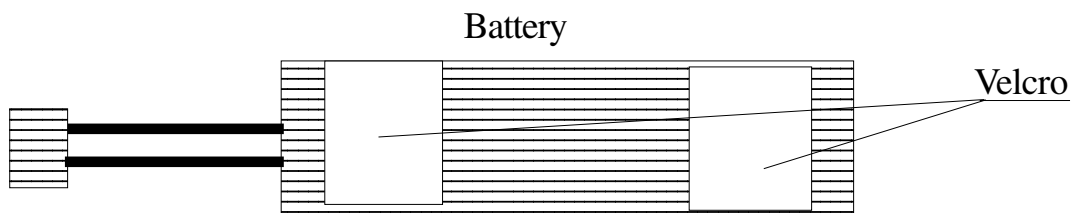

Figure 14

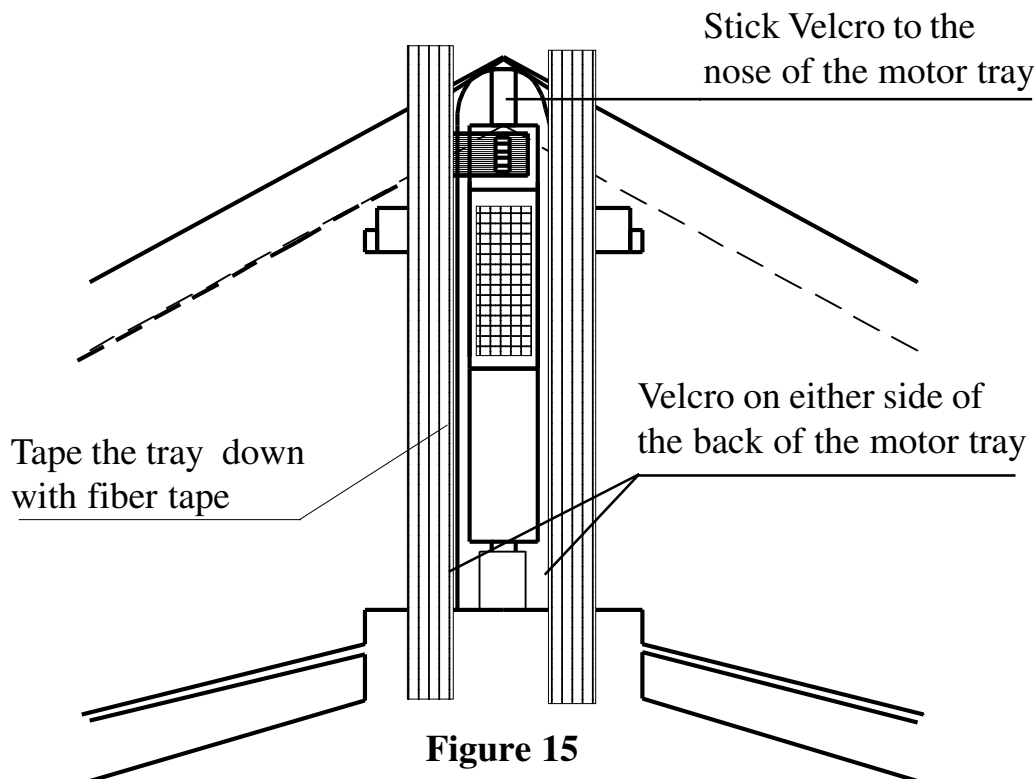

Figure 15

(See Figure 16) Punch-out and separate the two nested winglets. Punch-out the 1 1/4" x 1/4" slot in the winglet.

(See Figure 17) Put a piece of fiber filament tape through the slot to the top of the wing and wrap it around to the bottom of the wing. Add two more pieces of tape to secure the winglet in place. Make sure that the elevon will not bind against the winglet as it moves.

The winglets are at the very back of the airframe. The tape method of fastening is both light and strong. If a different winglet fastening system is preferred, keep the weight down to the weight of three short strips of tape.

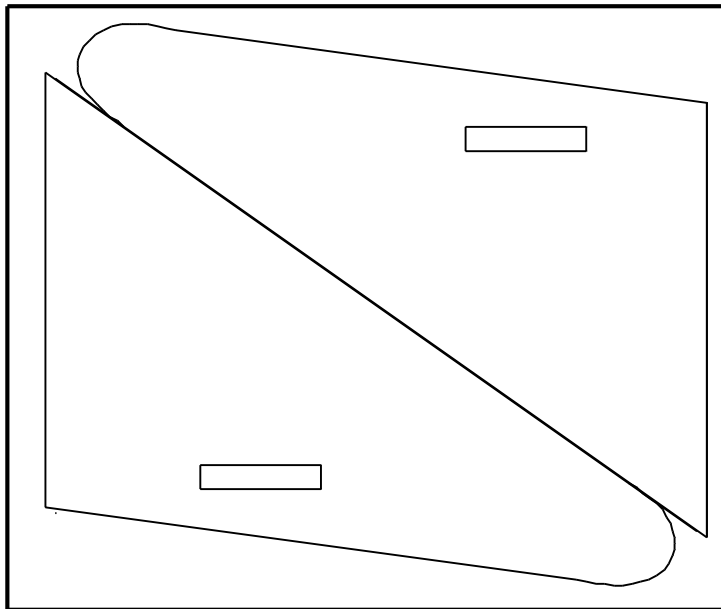

Figure 16

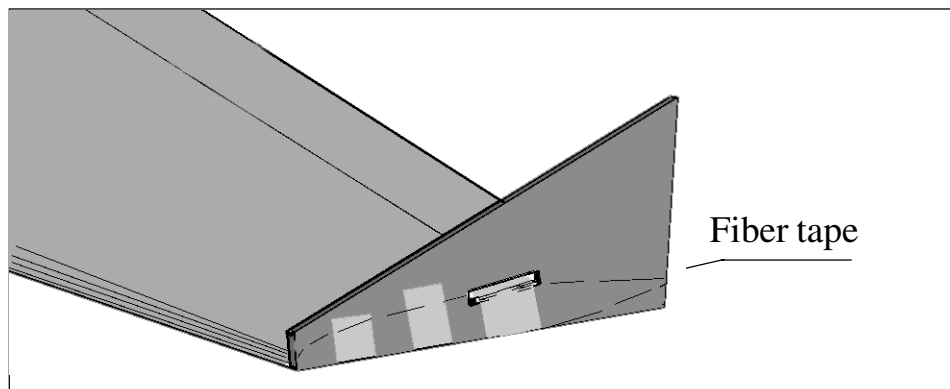

Figure 17

(See **Figure 18**) Lay the wing bottom-side-up. Tape a 1/4" dowel directly over the spar. A round pencil or ball-point pen can be used. Place the wing right-side-up on a flat surface. Balance is achieved when the wing balances momentarily on the pencil. The battery bay is longer than the battery. Move the battery forward or backward to balance. Glue a shim in front of the battery to the size of the empty space.

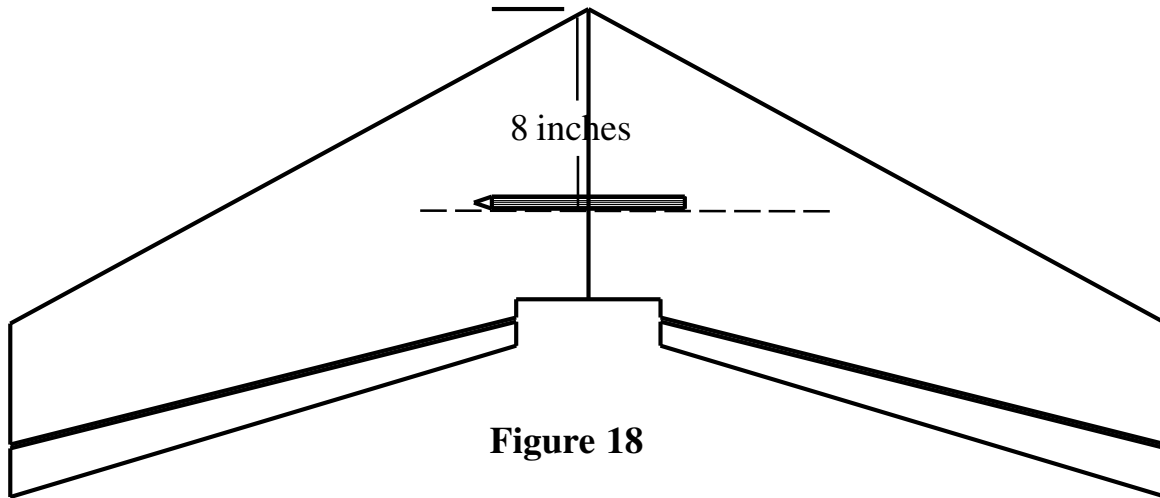

Figure 18

(See **Figure 19**) With the TX on and the battery plugged in, check the elevon neutral setting by laying a straight edge under the wing at the trailing edge. The elevons should appear to have 2 or 3 degrees of reflex (up elevator). This can best be accomplished by setting the elevator trim on the transmitter to zero and adjusting the clevises to the proper position.

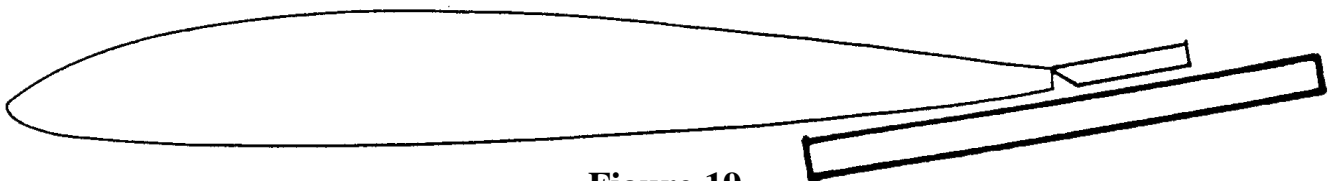

Figure 19

Set the trim and throw. Move the transmitter aileron stick from full right to full left (not up or down). The elevon throw should be 3/8" in each direction measured 1" from the tip (no differential) When moving the elevator stick full up to full down, the throw should be 3/8" in each direction.

Reverse the prop. The prop must be reversed to operate in the reverse direction. The raised lettering on the propeller blades should be outboard on the spinner side. Remove the spinner and hub. Hold the prop by the blades spinner side up. Press it on a flat surface. Grip the spinner and gently twist and pull the hub from the prop. Reverse the prop and replace the hub so that the raised lettering is on the spinner side of the prop, outside and away from the motor.

First time motor power-up

The following steps are provided for a safe first time motor power-up. Do not press the prop onto the motor shaft yet. Test the motor hookup before the prop is installed. Make sure that the battery is charged. The batteries are not shipped with a charge.

NOTE: Always turn the transmitter (TX) on before connecting the battery and disconnect the battery before turning off the TX.

SANYO RECOMMENDS CHARGING THE KR1700AE CELL AT A RATE UP TO 1 AMP. FOR THE LONGEST BATTERY LIFE. 1 AMP WILL CHARGE THE 8 CELL BATTERY IN TWO HOURS. AT THE RISK OF A SHORTER BATTERY LIFE, SOME MODELERS REGULARLY CHARGE THEM FOR 40 MINUTES AT 2 AMPS.

1. Remove the prop and make sure that the motor is seated and securely attached to the motor mount.
2. Make sure that the reverse switch for the motor stick on the transmitter is in the normal position. Not reversed!
3. Push the motor control stick on the transmitter to the full off position.
4. Push the motor control stick trim lever to the full down position.
5. Turn the transmitter power on. Check the output meter for battery condition.
6. Secure the charged 8 cell battery in place with the Velcro tabs.
7. Check that the ESC signal lead is in the motor slot of the receiver.
8. Position yourself with the nose of the airplane pointed at you. Plug the battery into the electronic speed control (ESC).
9. Turn the ESC switch to the on position.
10. Move the trim lever for the motor control stick slowly upward to the center position. The motor should not move.
11. Move the motor control stick slowly upward. The motor should run faster the further up the stick is moved. The motor should turn counter clockwise when observed from the front.
12. Unplug the battery from the ESC. Press the prop onto the motor shaft. Rotate the prop to make sure it is clear of any obstructions.

Preflight check and glide test

Do a preflight check before every flight. Always turn the transmitter power on before the motor battery in the airplane is plugged in. Make sure that the motor control stick is in the full down position. Make sure that the controls are working properly. Check the trim levers on the transmitter. Pull the control stick back and observe that both elevons move upward. Push the control stick to the right and observe the right elevon moves up and the left elevon moves down. Hold the Zagi-400 X securely by the nose. Move the throttle stick to the half throttle position momentarily. The first glide test should be done on flat land in a light breeze. The Zagi-400 X should be held by the nose with your palm up over your head and your thumb wrapped around to the top. **(See figure 20)** Hold the Zagi-400 X over your head with the nose pointed straight ahead. Run slowly into the wind. Give it a gentle push STRAIGHT AHEAD. Do not point the nose upward. Correct the flight path with the radio control stick. The test is successful when the Zagi-400 X flies straight ahead with a slow sink rate to a sliding landing. If the Zagi-400 X turns in either direction after the launch, compensate by adding 2 or 3 clicks of trim in the opposite direction with the trim lever below or next to the control stick. If the Zagi-400 X pitches up and immediately dives, add 2 or 3 clicks of down trim. Repeat the glide test until the Zagi-400 X flies straight ahead with a slow sink rate to a sliding landing. Increase the launch speed each time to provide longer control flights.

First flight

Check the frequencies (channel number) of all pilots within visual range before turning on your transmitter. Turning on your transmitter with the same channel number as someone who is flying will certainly cause his plane to crash.

The Zagi-400 X is capable of high speed. Flights at a high rate of speed can cause considerable damage to someone or something if a collision occurs. Please exercise caution while flying. **It is recommended that you join the Academy of Model Aeronautics (AMA) (1-800-435-9262) to provide insurance, awareness of safe flying practices, and knowledge of what's going on in the modeling field. At some flying sites it is mandatory that you be a member of the AMA.**

Do not launch the Zagi-400 X with the motor running. Hold the Zagi-400 X by the nose with your palm up over your head and your thumb wrapped around to the top. **(See Figure 21)** Take a step or two forward and give the Zagi-400 X a good strong throw into the wind. A follow through with a little finger tip will increase the launch speed. Slide the throttle stick to the full forward position when the Zagi-400 X is a comfortable distance from the ground. Get some altitude and experiment with some throttle settings. Full motor is fun but will use up the battery quickly.

Good luck,

JT

Battery Life and Power Management

Battery life is determined by two main factors; charging and discharging. Both of these functions produce heat. Warm is okay, hot isn't. A hot battery has either been charged or discharged too fast. First, charging. Make sure that the charger is designed to charge the number of cells being charged. The best type of charger is the peak detector type. These chargers will charge the battery to peak at a pre-selected rate then drops to a trickle. Chargers with timers will often over charge batteries causing excessive heat. Manufacturers recommend charging batteries at the rated capacity *i.e.*, a 500 mAh battery should be charged for one hour at 500 mAh. The exception to this is the batteries with the letter "R" at the end of the designation (500AR, or 2000SCR). The "R" means rapid charge and discharge. "R" cells are either very expensive or not available. Hobbyists are notorious battery abusers. Batteries that are not designed for rapid charge are routinely over charged by charging and discharging them too fast. NiCad cells have a finite number of cycles. Abuse will decrease the number of cycles. Electric flight hobbyists are willing to accept the shortened life of the batteries for performance. There are ways to cut these losses. Don't charge at a rate more than twice the designated capacity of the battery. Don't charge a hot battery. Get enough batteries to fly one, cool one, and charge one. A way to speed up the cycle is to make a 12 volt field battery cooler. Tape a 12 VDC muffin fan to a 6 inch length of 2 inch PVC pipe. (See Figure 19) The Muffin fan is available at Radio Shack or find an old computer power supply fan (but make sure it's designed for 12 VDC and not 110 VAC).

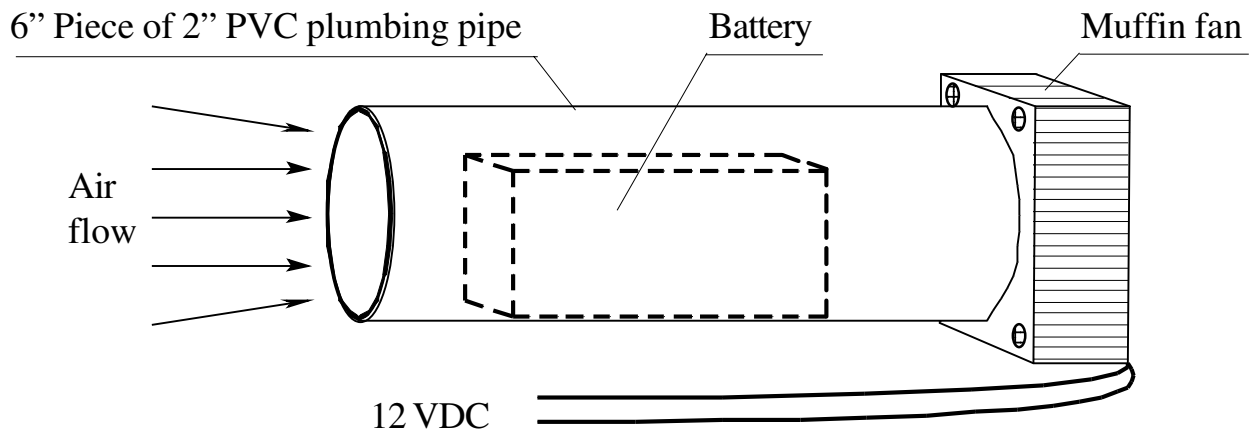

Figure 20

Discharging the battery at the rate of 10 to 15 amps is the other way electric flight hobbyists abuse batteries. These high discharge rates produce heat. Again there are ways to cut your losses. Airflow over the battery during flight will help. Vent holes in the cowling is a good idea. But more important is the throttle settings during the flight. Full bore for the entire flight is definitely too hot. Try some throttle off time and some half throttle time. This will extend the flight time and battery life.

MODS

The challenge of making any modifications on flying wings is the trade-off between the advantage and the penalty. Structural modifications made to the airframe should be made with caution. Since most mods involve adding weight, and more than likely behind the CG, mods should be avoided. If care is taken in the building process, the weight will be right on the manufacturers listed weight. Mods made to save weight are the best approach to building. Having said that, Here's a few mods that will work in a positive way.

One way to save weight is to use as little of the adhesives and tapes as possible. Instead of thinking a little more tape or glue will make the airplane better, think how little of each will it take to make it as strong as it needs to be. Epoxy makes a heavy wing joint and the spar adhesive. The 3M Super #77 Spray Adhesive will make an adequate bond. Remember, you're only bonding to one pound foam. The foam will usually fail before the bond will. Saving weight on the elevons will reduce the need for nose weight. Some balsa elevons are heavier than others. Elevon weight can be reduced by shaping. If the elevons seem heavy replace the elevons supplied with the kit with extra light weight contest grade balsa. Winglets made of meat tray styrofoam are lighter than the stock material although not nearly as strong.

Covering materials like Ora Cover or Ultra Kote are heavier than tape. The lighter materials like Solar Film are light but not as strong as tape. There are some problems using iron-on covering materials. Heat shrink materials can distort the geometry of the wing. Designs can be made with the color tape by alternating colors in a variety of patterns without adding weight.

Changing the propeller to a different pitch or diameter will require a prop adapter. Once again that the dorky little white Gunther prop supplied with the kit tested better on the Zagi-400 motor than all other props available but you have to remember to reverse the hub. The Zagi-400 and the X are supplied with a balanced power system. Changing the prop will change the load on the ESC and the battery. The Zagi-20 ESC is rated at 20 amps continuous. The Zagi-400X with a 1700 mAh battery and the stock prop draw 12.5 amps at full throttle. So if the prop diameter or pitch is increased, the load could exceed the range of the 20 amp ESC. Trial and error can get expensive. The way to prop electrics is with the use of a watt meter. Astro Flight makes a "Super Whattmeter for outdoor R/C models" for \$55.00 from Trick R/C. This device will keep the smoke from escaping from the speed control. Another useful tool is a tachometer. Cermark makes a good tach for cheap. A simple thrust meter can be made with a small postal scale calibrated in ounces. A test stand setup with a wattmeter, a scale and a tach will take the guesswork out of balancing electric components.

Throwing the Zagi-400 X

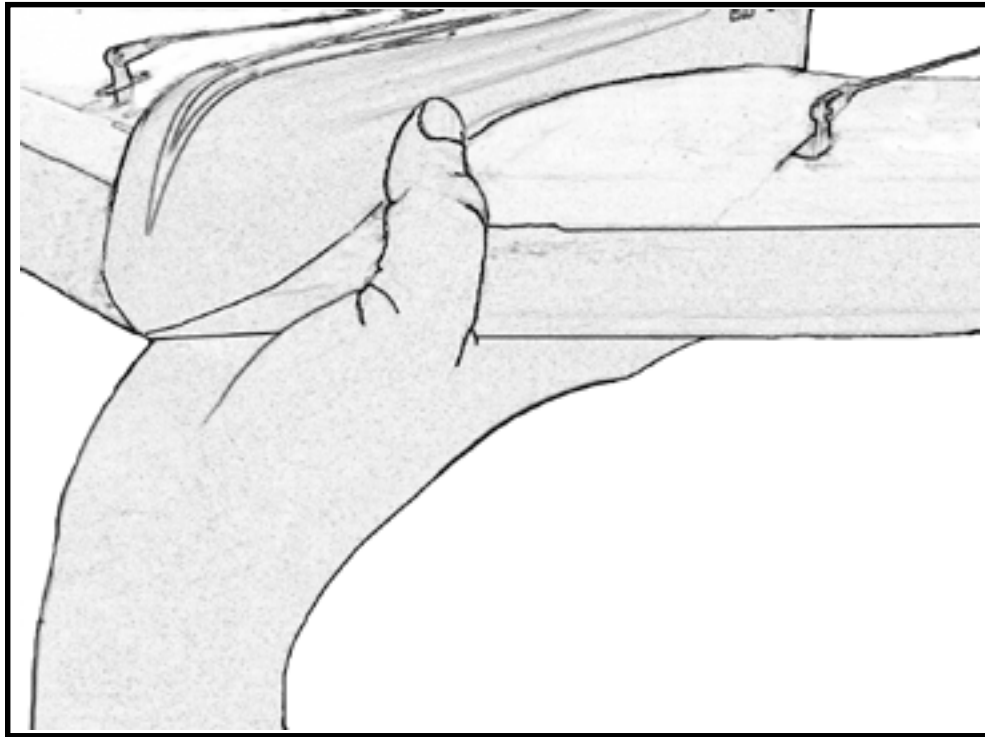

Figure 21

Hold the Zagi-400 X by the nose with your palm up over your head and your thumb wrapped around to the top. The secret to this launch is the energy you exert with your fingers in the follow through.

Trick R/C guarantees this kit to be free from defects in both workmanship and material at the date of purchase. This does not cover any components or parts damaged by use, misuse or modification. In no case shall Trick R/C's liability exceed the original price of the purchased kit.

Since Trick R/C has no control over the final assembly, no liability shall be assumed for any damage resulting from the use by the user of the final user-assembled product. By the act of using the final user-assembled product, the user accepts all resulting liability.



Zagi is a registered trademark of Trick R/C Products LLC
